

Ultralight 403

1^{PS}
Äquivalent

Für Angler und Abenteurer,
die auf nichts verzichten wollen



Die wichtigsten
Vorteile



Bedien-
elemente



Reichweiten und
Geschwindigkeiten



Technische
Daten und Maße



Sonder-
modelle

Ultralight 403

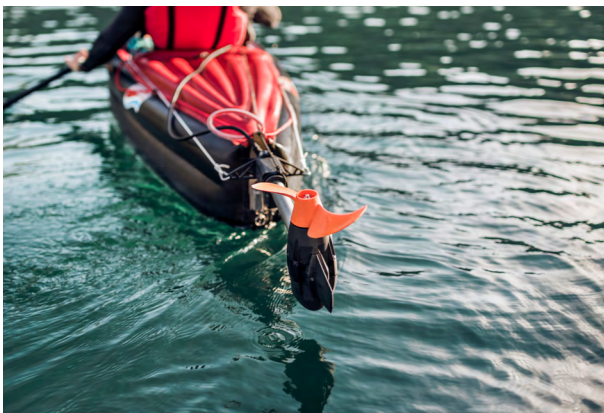

- + Bis zu 10 km/h schnell und bis zu 40 km weit fahren
- + Nur 8,9 kg Gewicht inklusive Akku
- + Bordcomputer mit Echtzeitanzeige verbleibender Reichweite, Geschwindigkeit, Ladestatus und vielem mehr
- + Langlebiger Lithium-Akku ohne Memory-Effekt mit verkürzter Ladedauer und USB-Anschluss
- + Kompatibel mit der Steueranlage aller gängigen Kajakmodelle
- + Höchste Sicherheit durch Not-Aus-Magnetchip, automatisches Not-Aus bei Kentern
- + Wasserdicht gemäß IP67
- + Wechselakku 915 Wh erhältlich



Ultralight 403



Einfaches Anlassen des Motors per Knopfdruck

+ Lenken/Kippen/Auto-Kickup: einfache Integration in die Steueranlage des Kajaks



+ Sicherheit durch Not-Aus-Magnetrip: stoppt bei Trennung sofort den Motor

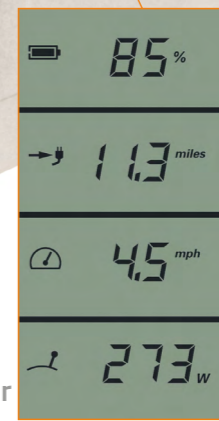

+ Langlebiger Lithium-Hochleistungs-Akku mit 320 Wh Kapazität (11 Ah bei 29,6 V). Integriertes Echtzeit-GPS und intelligentes Batterie-Management-System. Wasserdicht gemäß IP67. USB-Ladeanschluss für Bordlampe oder zum Aufladen von Handy und Kamera

+ Stufenloser elektronischer Gashebel mit Bordcomputer-Display informiert in Echtzeit über Batterieladestatus, Geschwindigkeit über Grund, Eingangsleistung und Restreichweite

Effizientes Propellerdesign für hohe Maximalgeschwindigkeit

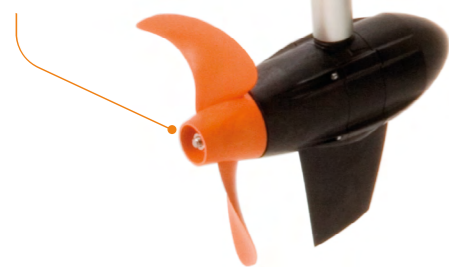

+ Hightech-Antrieb mit höchstem Wirkungsgrad: Die optimale Drehmomentkurve sorgt für höchste Effizienz bei jeder Geschwindigkeit. Mehr Leistung und größere Reichweite als alle anderen Elektromotoren in dieser Klasse - bei gleicher Batteriekapazität

+ Einfache Montage: Mit der im Lieferumfang enthaltenen Montage-Kugel passt der Ultralight 403 auf fast jedes Kajak. Für Kajaks der Hersteller Hobie, Wilderness, Rotomod und Grabner sind Sondermodelle von Motor und Kajak über das Händlernetzwerk des jeweiligen Anbieters erhältlich



» Die wichtigsten Vorteile

» Bedienelemente

» Reichweiten und Geschwindigkeiten

» Technische Daten und Maße

» Sondermodelle

Ultralight 403

Ultralight 403 mit integrierter Lithium-Batterie (29,6 V / 11 Ah)

Angelkajak Hobie Mirage Revolution (4,1 m / 26,3 kg)	Geschwindigkeit in km/h*	Reichweite in km*	Laufzeit in Stunden:Minuten
● ● ● Langsame Fahrt	4,2	35,2	08:20
● ● ● Halbgas	6,0	25,0	04:10
● ● ● Vollgas	9,3	7,4	00:48

Ultralight 403 mit integrierter Lithium-Batterie (29,6 V / 11 Ah)

Tourenkajak Prijon Prilite T470 (4,7 m / 23 kg)	Geschwindigkeit in km/h*	Reichweite in km*	Laufzeit in Stunden:Minuten
● ● ● Langsame Fahrt	4,2	42,0	10:00
● ● ● Halbgas	6,2	26,0	04:10
● ● ● Vollgas	9,8	7,8	00:48

* Abhängig unter anderem von Bootstyp, Beladung, Propeller und Umweltbedingungen. Angaben zu Geschwindigkeit und Reichweite ohne Gewähr.



Die wichtigsten Vorteile



Bedienelemente



Reichweiten und Geschwindigkeiten



Technische Daten und Maße



Sondermodelle

Ultralight 403

Technische Daten

Eingangsleistung in Watt	400
Vortriebsleistung in Watt	180
Vergleichbarer Benzin-Aussenborder (Wellenleistung)	1 PS
Vergleichbarer Benzin-Aussenborder (Schub)	2 PS
Maximaler Gesamtwirkungsgrad in %	45
Stand Schub in lbs*	33
Integrierte Batterie	320 Wh Li-Ion
Nennspannung in Volt	29,6
Ladeendspannung in Volt	33,6
Gesamtgewicht in kg	8,9
Gewicht Motor ohne Akku in kg	4,4
Gewicht integrierter Akku in kg	4,5
Schaftlänge in cm	45
Steuerung	Gashebel
Kippvorrichtung	manuell mit Auflaufschutz
Integrierter Bordcomputer	Ja
Stufenlose Vorwärts-/Rückwärtsfahrt	Ja



* Torqeedo Stand Schubangaben beruhen auf Messungen entsprechend weltweit gültiger ISO-Richtlinien. Stand Schubangaben von Angelmotoren werden typischerweise abweichend gemessen und kommen deshalb zu höheren Werten. Um Torqeedo Stand Schübe mit konventionellen Angelmotoren zu vergleichen, können zirka 50% auf die Torqeedo Stand Schubangabe addiert werden.



Die wichtigsten Vorteile



Bedienelemente



Reichweiten und Geschwindigkeiten



Technische Daten und Maße



Sondermodelle

Ultralight 403

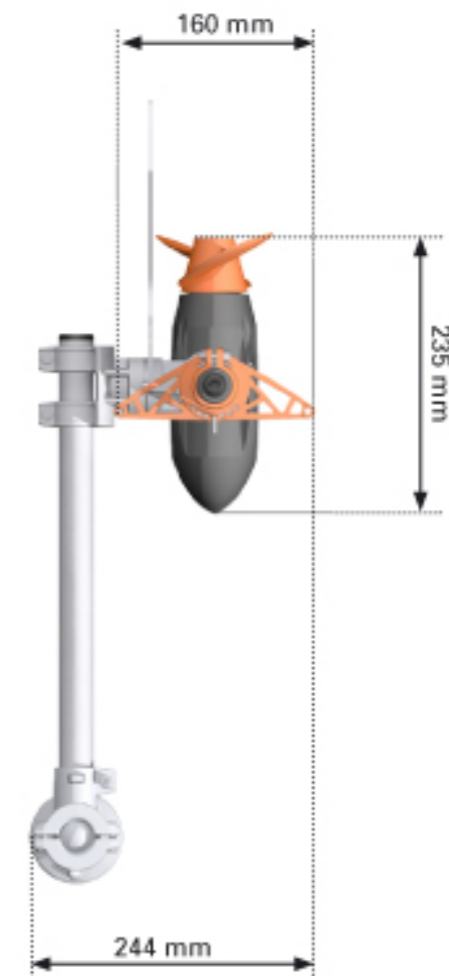
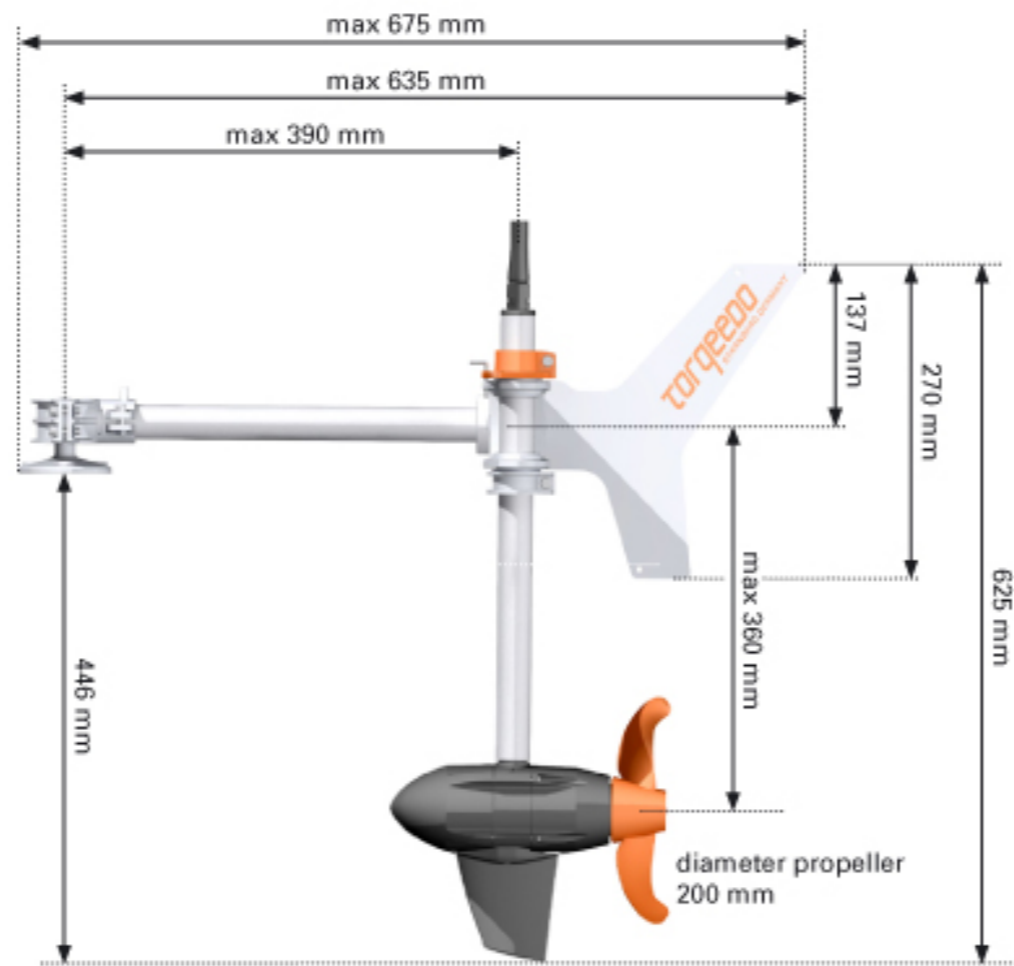

Die wichtigsten Vorteile



Bedienelemente



Reichweiten und Geschwindigkeiten



Technische Daten und Maße



Sondermodelle

Ultralight 403

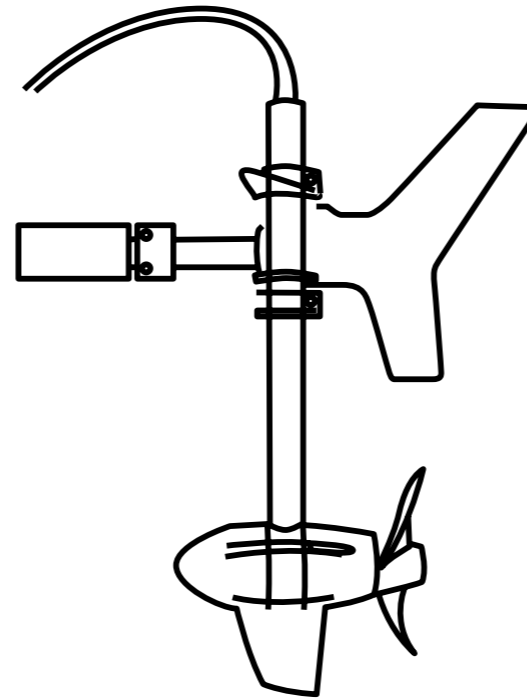
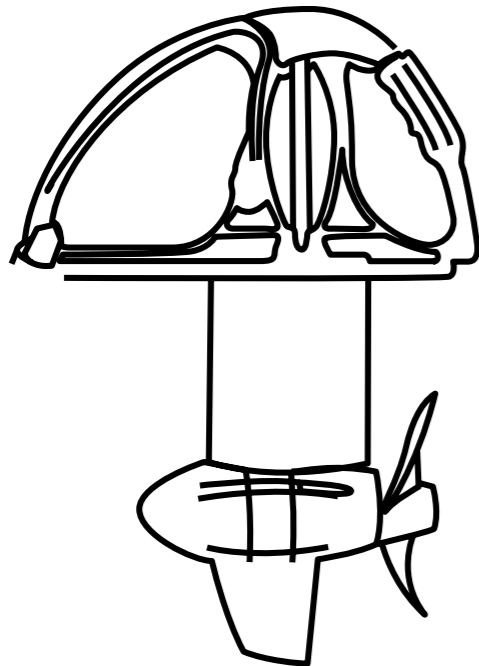

Die wichtigsten Vorteile



Bedienelemente



Reichweiten und Geschwindigkeiten



Technische Daten und Maße



Sondermodelle

Ultralight 403

1^{HP}
Equivalent

For anglers and adventurers unwilling to compromise



» Main advantages

» Operating elements

» Speed, range, run time

» Technical data & measures

» Special edition

Ultralight 403

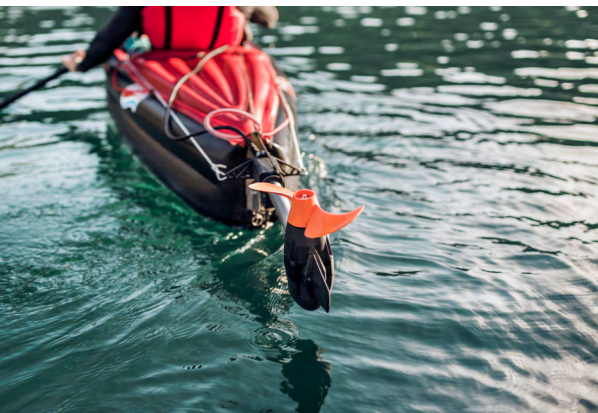

- + Capable of travelling at up to 10 km/h and covering up to 40 km
- + Only 8.9 kg total weight including battery
- + On-board computer with real-time display of remaining range, speed, charging status and much more
- + Long-lasting lithium battery without memory effect with shorter charging time and USB connection
- + Compatible with the steering system of all popular kayak models
- + Safe thanks to emergency magnetic kill switch that cuts the motor if you capsize
- + Waterproof to IP67
- + Spare battery 915 Wh available

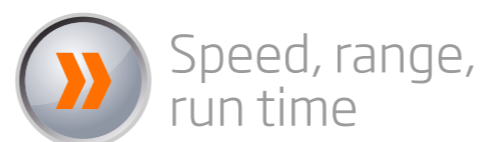

Ultralight 403

Simple motor start at the press of a button

+ **Steering /tilting /auto-kick-up:** Simple integration with the kayak's steering system

+ **Very safe thanks to emergency magnetic kill switch that stops the motor when disconnected**

+ **Long-lasting, high-performance lithium battery** with 320 Wh (11 Ah at 29.6 V). Integrated real-time GPS and intelligent battery management system. Waterproof to IP67. USB charging connection - for an on-board light or for charging mobile phone and camera.

+ **Stepless electronic throttle with on-board computer display** provides real-time information on battery charge status, speed over ground, input power and remaining range

+ **Simple mounting:** The Ultralight 403 can be mounted on just about any kayak with the mounting ball provided. There are special models available for kayaks from Hobie , Wilderness, Rotomod and Grabner available via the dealer network of the relevant kayak producer.

Efficient propeller design for maximum speed

+ **High-tech propulsion with maximum efficiency:** Optimal torque characteristics ensure maximum efficiency at any speed. Greater performance and greater range than all other electric motors in this class - with the same battery capacity.

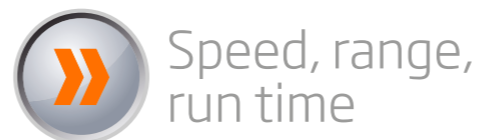
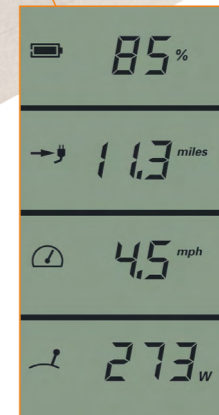

Ultralight 403

Ultralight 403 with integrated lithium battery (29.6 V / 11 Ah)

Fishing kayak (4.1 m / 26.3 kg, Model: Hobie Mirage Revolution)	Speed in km/h*	Range in km*	Running time in hh:mm
● ○ ○ Slow	4.2	35.2	08:20
● ● ○ Half throttle	6.0	25.0	04:10
● ● ● Full throttle	9.3	7.4	00:48

Ultralight 403 with integrated lithium battery (29.6 V / 11 Ah)

Touring kayak (4.7 m / 23 kg, Model: Prijon Prilite T470)	Speed in km/h*	Range in km*	Running time in hh:mm
● ○ ○ Slow	4.2	42.0	10:00
● ● ○ Half throttle	6.2	26.0	04:10
● ● ● Full throttle	9.8	7.8	00:48

* Depends on type of boat, load, propeller and conditions. Speed and range indications do not represent a legal guarantee.

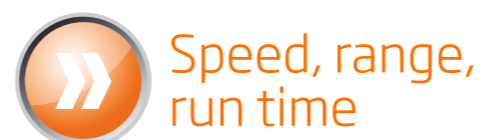

Ultralight 403

Technical data

Input power in watts	400
Propulsive power in watts	180
Comparable petrol outboard (shaft power)	1 HP
Comparable petrol outboard (thrust)	2 HP
Maximum overall efficiency in %	45
Static thrust in lbs*	33
Integrated battery	320 Wh Li-Ion
Nominal voltage	29.6
Final charging voltage	33.6
Total weight in kg	8.9
Motor weight without battery, in kg	4.4
Weight of integrated battery, in kg	4.5
Shaft length in cm	45
Control	Throttle
Steering	Provision to connect to kayak rudder; lockable
Tilting device	Manual, with impact protection
Trim device	-
Stepless forward/reverse drive	Yes
Integrated on-board computer with display	Yes

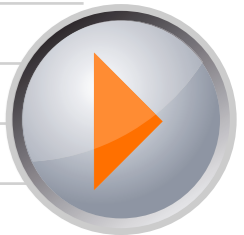

* Torqeedo static thrust measurement is based on internationally accepted ISO standards. Static thrust figures for conventional trolling motors are typically measured differently, which results in higher values. To compare Torqeedo static thrust data with conventional trolling motors, add approximately 50% to the Torqeedo static thrust values.

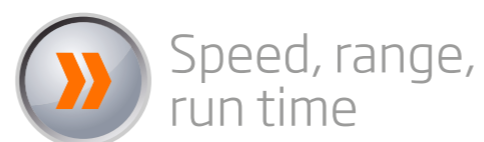

Ultralight 403

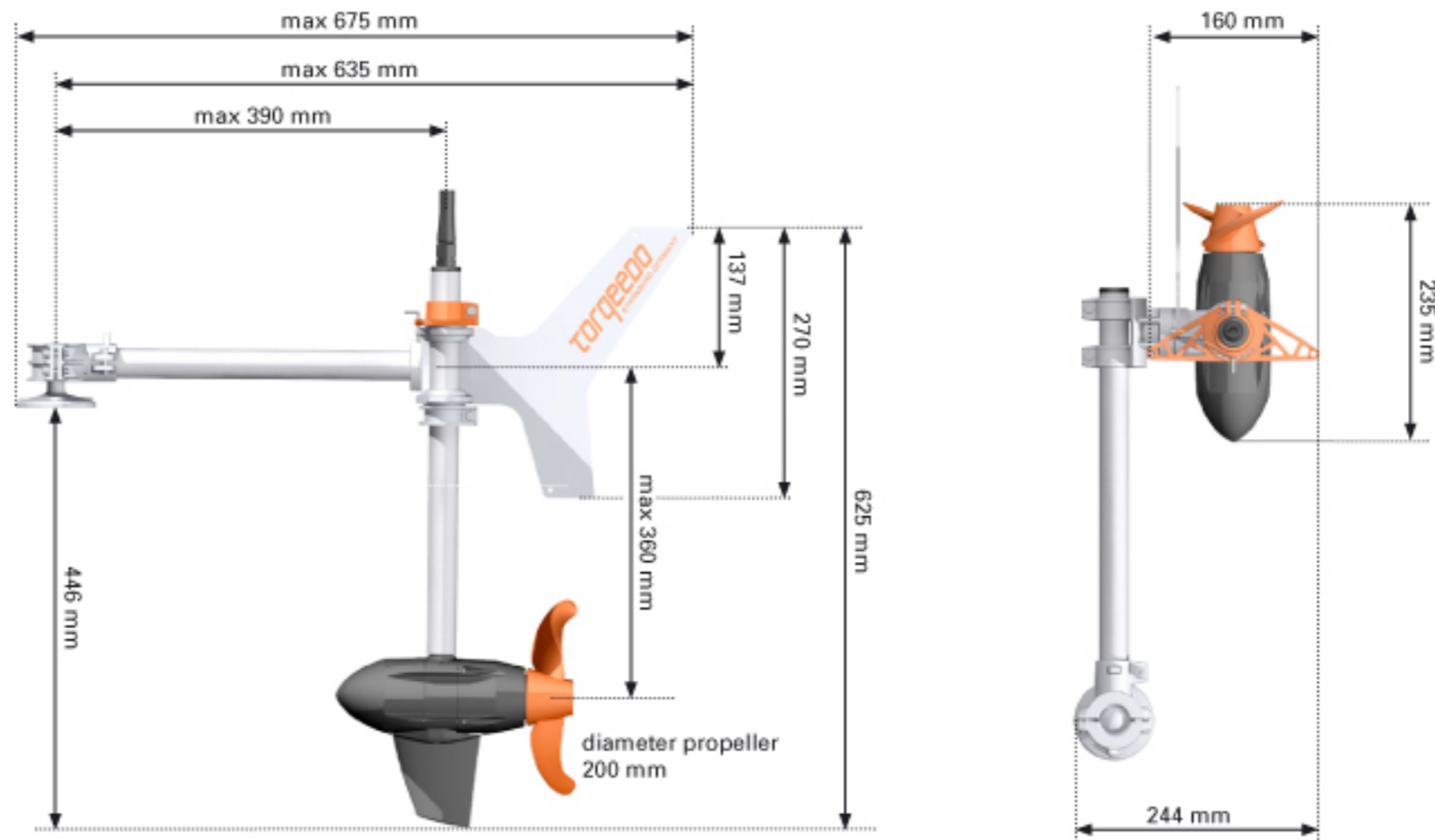

Main advantages



Operating elements

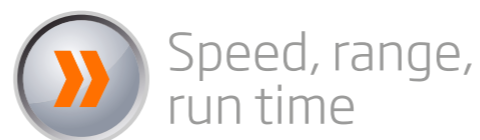

Speed, range, run time



Technical data & measures



Special edition

Ultralight 403

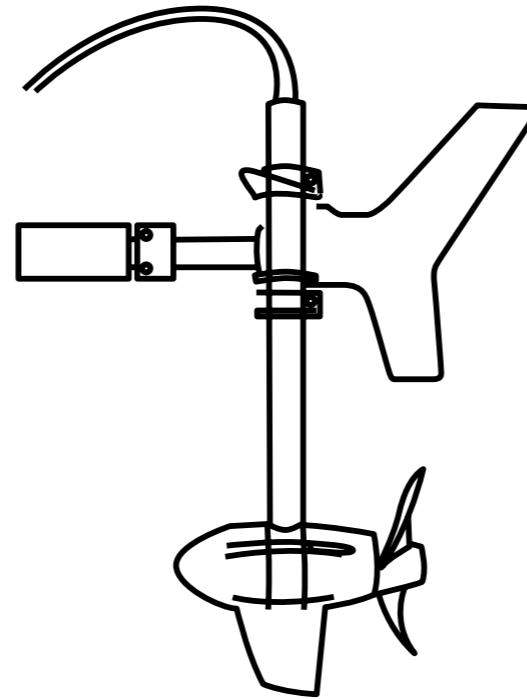
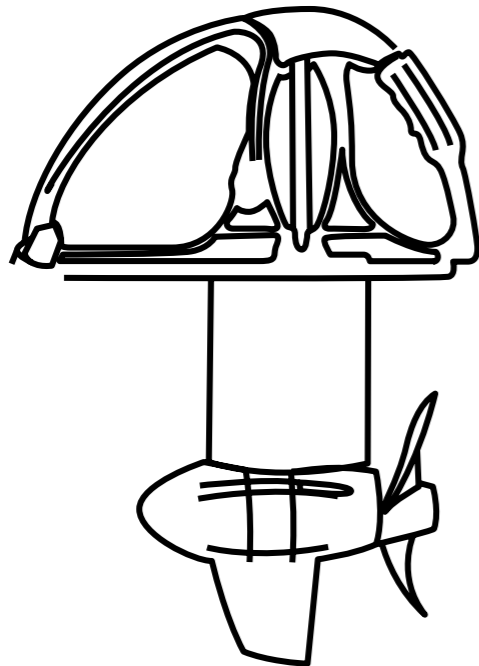

 Main advantages

 Operating elements

 Speed, range, run time

 Technical data & measures

 Special edition

Ultralight 403

1^{CV}
Équivalent

La pêche, l'aventure
et tout le confort



Les atouts



Éléments de commande



Autonomie et vitesse



Caractéristiques et cotes



Modèles spéciaux

Ultralight 403

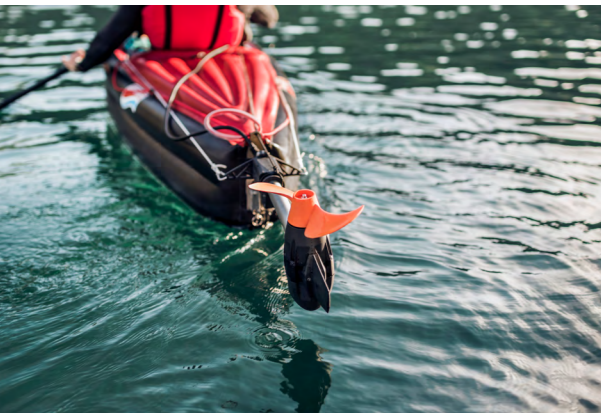

- + Jusqu'à 10 km/h et 40 km d'autonomie
- + 8,9 kg seulement avec la batterie
- + Ordinateur de bord avec affichage en temps réel de la distance restante, de la vitesse, de l'état de charge, etc.
- + Batterie lithium sans effet mémoire à recharge rapide, avec prise USB
- + Intégration au gouvernail de tous les kayaks courants
- + Haute sécurité par clé magnétique, coupure automatique si le bateau chavire
- + Étanche IP67
- + Batterie de recharge 915 Wh en vente



Les atouts



Éléments de commande



Autonomie et vitesse



Caractéristiques et cotes



Modèles spéciaux

Ultralight 403



Bouton de démarrage

+ Direction/Relevage/Relevage automatique : intégrables au gouvernail du kayak.

+ Sécurité par clé magnétique : le moteur s'arrête dès qu'elle n'est plus sur la manette.

+ Batterie lithium haute capacité de 320 Wh (11 Ah pour 29,6 V). Suivi GPS en temps réel et système de gestion intelligent. Étanche IP67, prise USB pour lampe de bord, téléphones portables ou appareils photos.

+ Manette de commande électronique à réglage continu avec infos de l'ordinateur de bord en temps réel : état de charge de la batterie, vitesse fond, puissance au moteur et distance restante.

Hélice optimisée : vitesse maximale élevée

+ Propulsion high-tech à très haut rendement à tous les régimes grâce à la courbe de couple idéale. Plus grande puissance et plus grande autonomie à partir d'une batterie que tout autre moteur électrique de cette catégorie.

+ Montage simple : l'Ultralight 403 se fixe sur pratiquement n'importe quel kayak à l'aide de la boule de montage fournie avec le moteur. Pour les kayaks Hobie, Wilderness, Rotomod et Grabner, il existe des moteurs et des systèmes de montage spéciaux en vente chez les distributeurs agréés.



» Les atouts

» Éléments de commande

» Autonomie et vitesse

» Caractéristiques et cotes

» Modèles spéciaux

Ultralight 403

Ultralight 403 avec batterie lithium intégrée (29,6 V / 11 Ah)

Kayak de pêche (4,1 m / 26,3 kg, modèle Hobie Mirage Revolution)	Vitesse en km/h*	Autonomie en km*	Autonomie en h:min
Bas régime	4,2	35,2	08:20
Mi-régime	6,0	25,0	04:10
Plein régime	9,3	7,4	00:48

Ultralight 403 avec batterie lithium intégrée (29,6 V / 11 Ah)

Kayak de randonnée (4,7 m / 23 kg, modèle Prijon Prilite T470)	Vitesse en km/h*	Autonomie en km*	Autonomie en h:min
Bas régime	4,2	42,0	10:00
Mi-régime	6,2	26,0	04:10
Plein régime	9,8	7,8	00:48

* Suivant le type de bateau, le chargement, l'hélice et les conditions d'environnement. Vitesses et autonomies indiquées sous toutes réserves.



Ultralight 403

Caractéristiques

Puissance d'entrée en watts	400
Puissance de propulsion en watts	180
Équivalent hors-bord thermique de (puissance de propulsion)	1 CV
Équivalent hors-bord thermique de (poussée)	2 CV
Rendement global maximum en %	45
Poussée statique en lbs*	33
Batterie intégrée en Wh	320
Tension nominale en volts	29,6
Tension finale de charge en volts	33,6
Poids total en kg	8,9
Poids du moteur sans la batterie en kg	4,5
Poids de la batterie intégrée en kg	4,5
Longueur d'arbre en cm	45
Commande	Manette de commande à distance
Relevage	Manuel + automatique lorsque le moteur touche le fond
Accélération continue AV/AR	Oui
	Oui

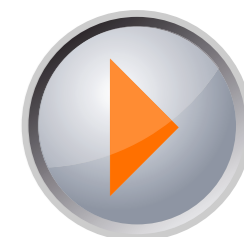

* Les poussées statiques mentionnées par Torqeedo ont été mesurées par procédés conformes aux directives ISO mondialement reconnues. Les poussées statiques des moteurs de traîne étant généralement évaluées par d'autres procédés aboutissant à des valeurs plus élevées, il convient de majorer les valeurs indiquées par Torqeedo d'environ 50 % pour pouvoir les comparer à celles des moteurs de pêche classiques.



Ultralight 403

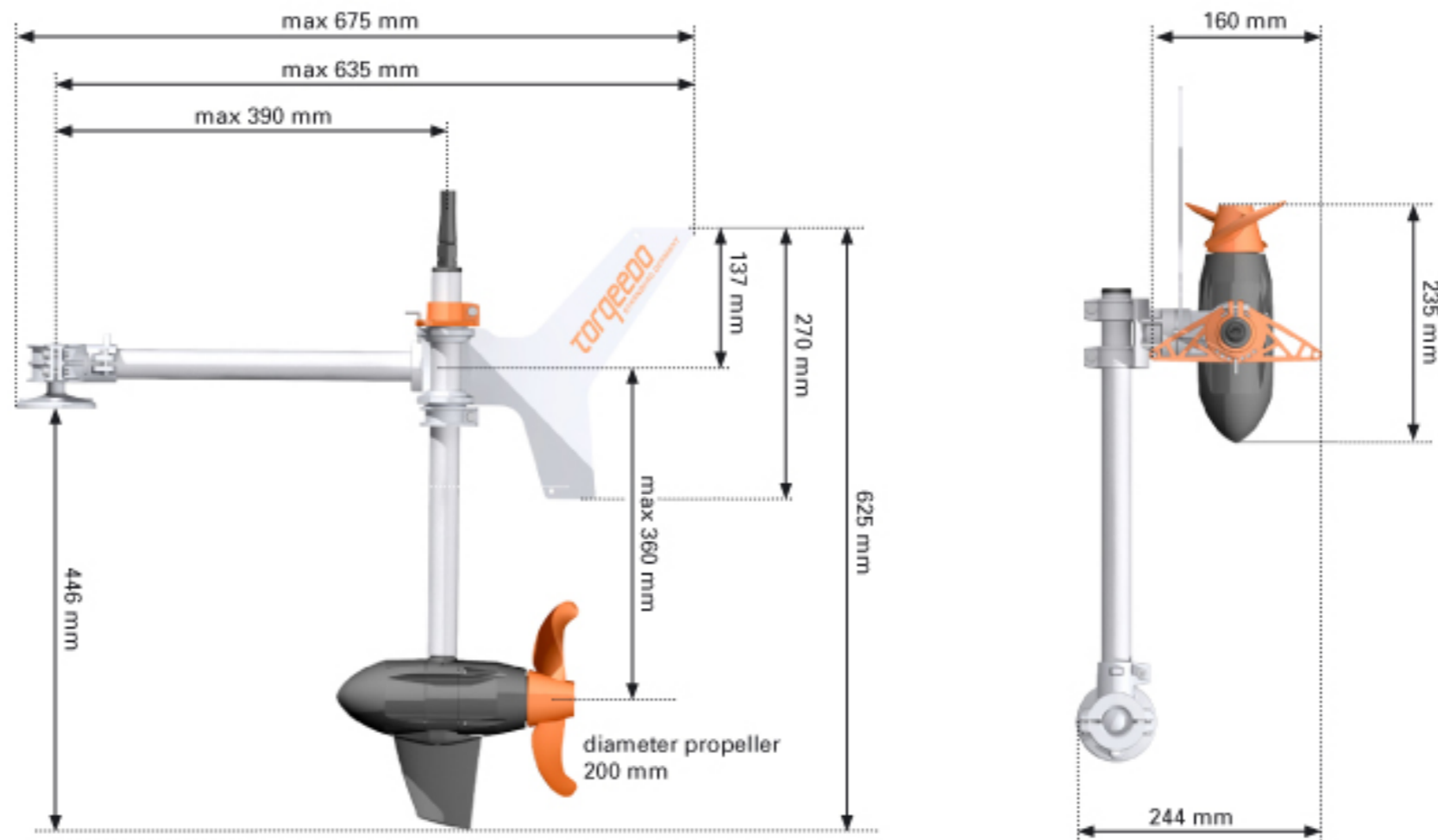

Les atouts



Éléments de commande



Autonomie et vitesse



Caractéristiques et cotes



Modèles spéciaux

Ultralight 403

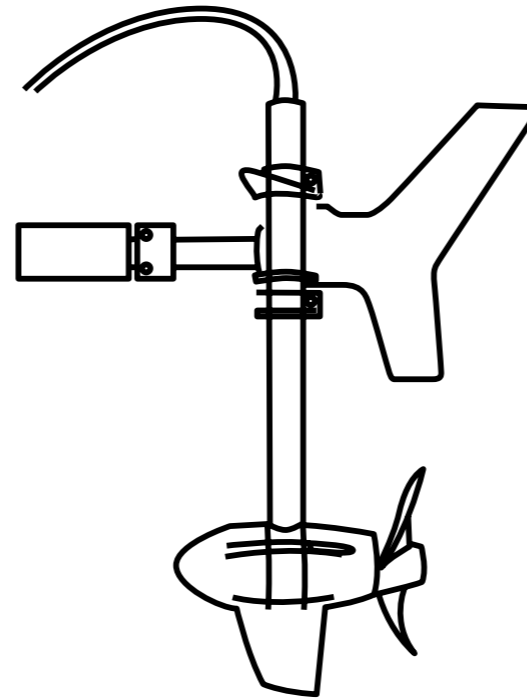
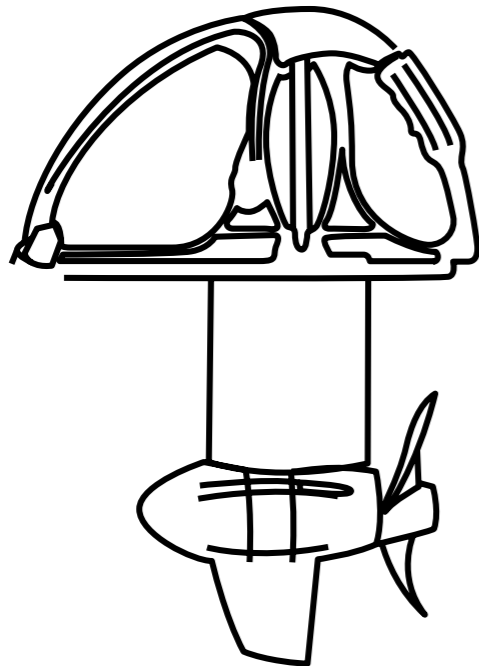

 Les atouts

 Éléments de commande

 Autonomie et vitesse

 Caractéristiques et cotes

 Modèles spéciaux

Ultralight 403

1^{CV}
equiparable

Para pescadores y aventureros que no desean renunciar a nada



Las claves



Elementos de mando



Velocidad, distancia, autonomía



Datos técnicos



Modelos adaptados

Ultralight 403

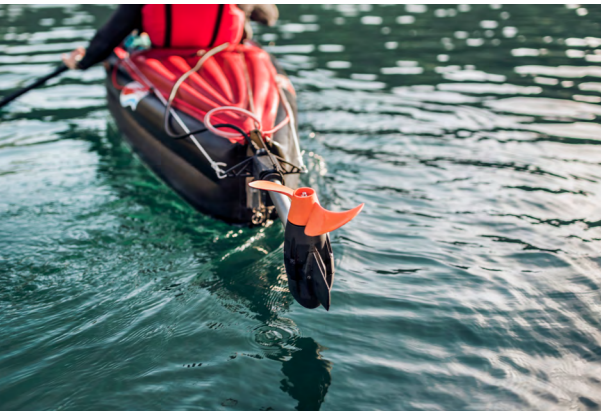

- + Permite alcanzar velocidades de hasta 10 km/h y recorrer hasta 40 km
- + Solo pesa 8,9 kg incluida la batería
- + Ordenador de a bordo con indicación actualizada de la autonomía, la velocidad, el estado de carga y muchos más datos
- + Batería de litio de larga vida útil sin efecto memoria con tiempo de carga reducido y conexión USB
- + Compatible con el sistema de control de la gran mayoría de los modelos de kayaks disponibles
- + Máxima seguridad gracias a la llave hombre al agua, paro automático en caso de zozobra
- + Estanco al agua según IP67
- + Batería de recambio 915 Wh obtenible



Las
claves



Elementos
de mando



Velocidad, distancia,
autonomía



Datos
técnicos



Modelos
adaptados

Ultralight 403

Arranque sencillo con solo pulsar un botón

+ Timón/auto elevable/auto-stop en caso de vuelco: Fácil de integrar en el sistema de control del kayak



+ Máxima seguridad gracias a la llave hombre al agua: Detiene el motor de inmediato al separarse

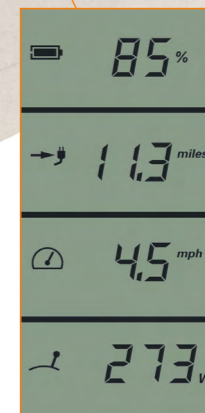

+ Batería de litio de alto rendimiento con larga vida útil y una capacidad de 320 Wh (11 Ah a 29,6 V). GPS integrado con datos en tiempo real y sistema inteligente de gestión de la batería. Estanco al agua según IP67. Conexión USB para alimentar una lámpara o recargar el teléfono móvil y la cámara

+ Palanca de acelerador electrónico de progresión continua con pantalla del ordenador de a bordo que proporciona en todo momento los datos relativos a la carga de baterías, velocidad GPS, consumo y autonomía restante

Hélice optimizada para alcanzar la máxima velocidad

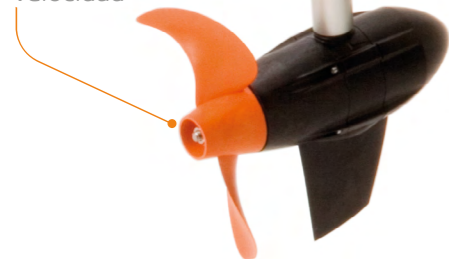

+ Sistema de propulsión de alta tecnología con una eficiencia máxima: La excelente curva de par motor de los motores Torqueedo permite alcanzar la eficacia más alta en cualquier velocidad. Más potencia y autonomía que otros motores eléctricos de esta categoría, a partir de la misma capacidad de baterías.

+ Instalación sencilla: Con ayuda de la bola de montaje suministrada, el Ultralight 403 se puede utilizar en casi todos los tipos de kayak. En el caso de kayaks de las marcas Hobie, Wilderness, Rotomod y Grabner se pueden adquirir modelos especiales del motor y de kayak en los distribuidores de la marca correspondiente



Ultralight 403

Ultralight 403 con batería de litio integrada (29,6 V / 11 Ah)

Kayak para pesca (4,1 m / 26,3 kg, modelo: Hobie Mirage Revolution)

	Velocidad en km/h	Autonomía en km	Autonomía en horas:minutos
--	-------------------	-----------------	----------------------------

● ● ● Velocidad lenta	4,2	35,2	08:20
-----------------------	-----	------	-------

● ● ● Velocidad media	6,0	25,0	04:10
-----------------------	-----	------	-------

● ● ● Velocidad máxima	9,3	7,4	00:48
------------------------	-----	-----	-------

Ultralight 403 con batería de litio integrada (29,6 V / 11 Ah)

Touring Kayac (4,7 m / 23 kg, modelo: Prijon Prilite T470)

	Velocidad en km/h	Autonomía en km	Autonomía en horas:minutos
--	-------------------	-----------------	----------------------------

● ● ● Velocidad lenta	4,2	42,0	10:00
-----------------------	-----	------	-------

● ● ● Velocidad media	6,2	26,0	04:10
-----------------------	-----	------	-------

● ● ● Velocidad máxima	9,8	7,8	00:48
------------------------	-----	-----	-------

* Según el tipo de embarcación, carga, hélice y condiciones ambientales. Datos de velocidad y autonomía sin garantía.



Las claves



Elementos de mando



Velocidad, distancia, autonomía



Datos técnicos



Modelos adaptados

Ultralight 403

Datos técnicos

Potencia de salida en vatios	400
Potencia de propulsión en vatios	180
Motores fueraborda de gasolina de referencia (potencia de propulsión)	1 CV
Motores fueraborda de gasolina de referencia (propulsión)	2 CV
Rendimiento máximo en %	45
Tracción a punto fijo en lbs*	33
Batería integrada (Li-Ion) en Wh	320
Tensión nominal en voltios	29,6
Tensión final de carga en voltios	33,6
Peso total en kg	8,9
Peso motor sin batería en kg	4,5
Peso batería integrada en kg	4,5
Longitud de la cola en cm	45
Mando	Caja de control remoto
Sistema basculante	manualmente con protección contra el encallamiento
Marcha avante/atrás regulables sin graduación	Sí
Ordenador de a bordo integrado	Sí

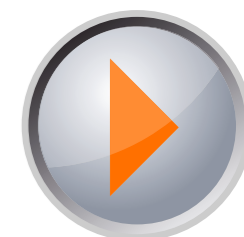

* Los datos de tracción a punto fijo de Torqeedo se basan en mediciones efectuadas según las normas ISO vigentes a nivel internacional. Los datos de tracción a punto fijo de motores de pesca se miden, por lo general, de forma diferente y, por lo tanto, arrojan unos resultados superiores. Para poder comparar la tracción a punto fijo de los motores de Torqeedo con los motores de pesca convencionales, hay que incrementar aprox. un 50% los datos de tracción a punto fijo de Torqeedo.



Las claves



Elementos de mando



Velocidad, distancia, autonomía



Datos técnicos



Modelos adaptados

Ultralight 403

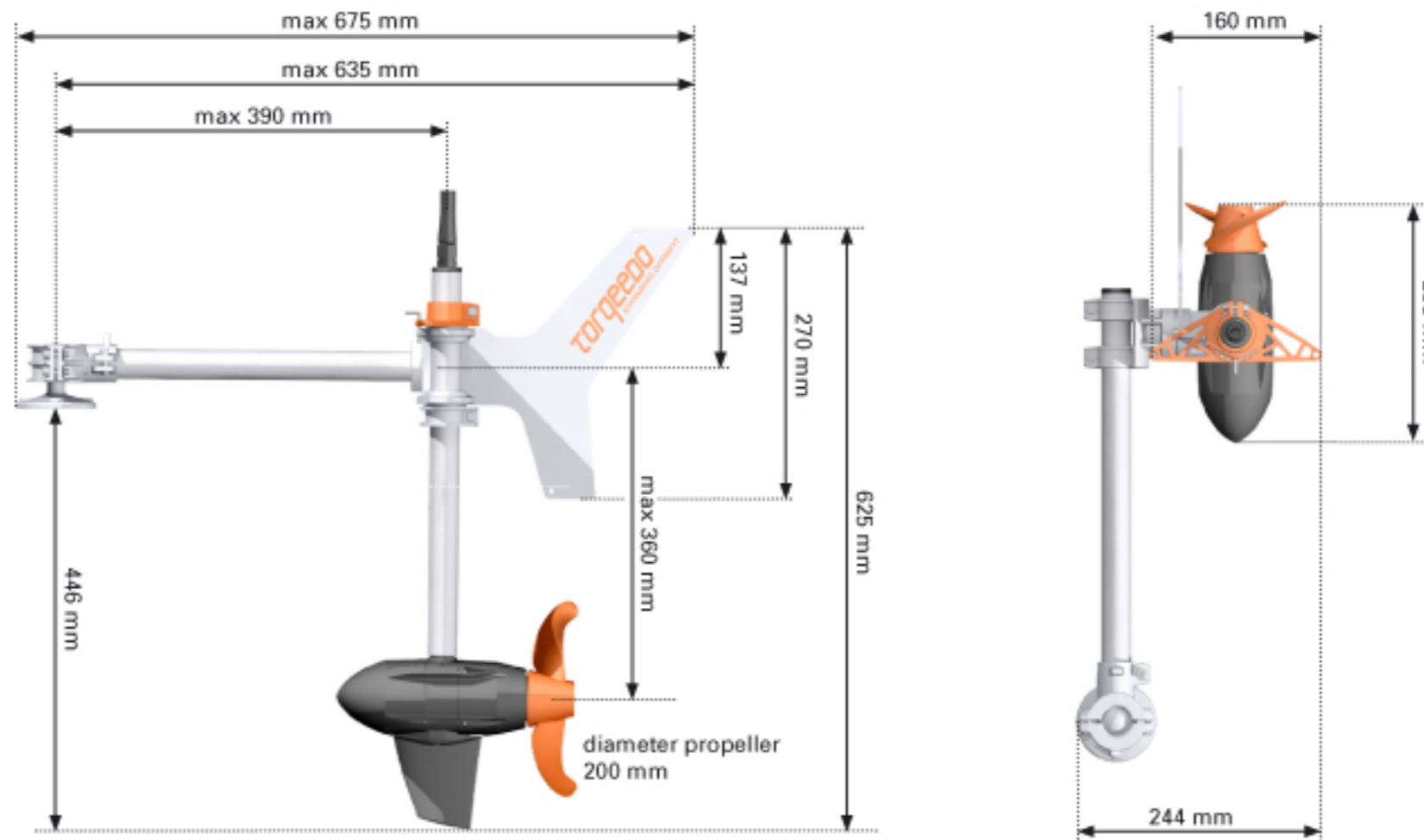

Las claves



Elementos de mando



Velocidad, distancia, autonomía



Datos técnicos



Modelos adaptados

Ultralight 403

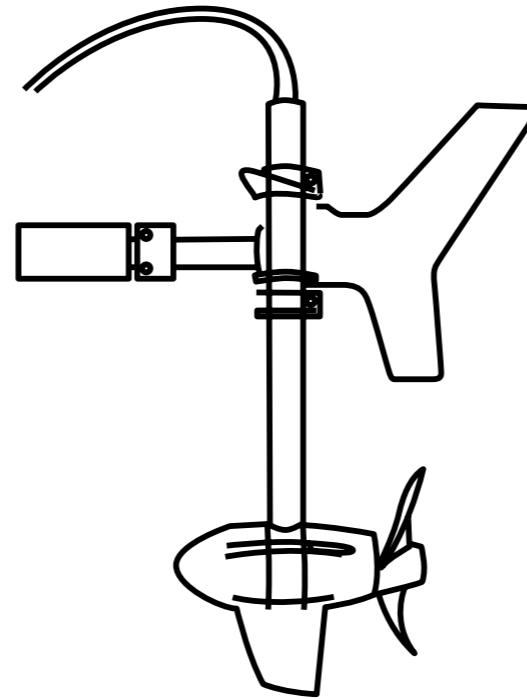
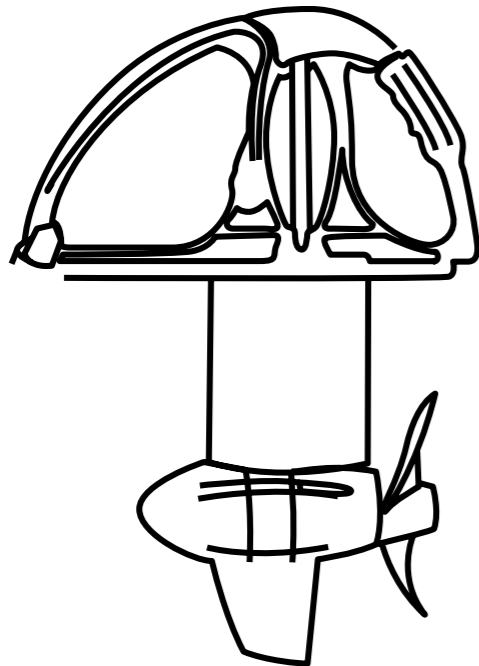

Las
claves



Elementos
de mando



Velocidad, distancia,
autonomía



Datos
técnicos



Modelos
adaptados