

T4.180 engine

132.5 kW (180 hp) at 3400 rpm

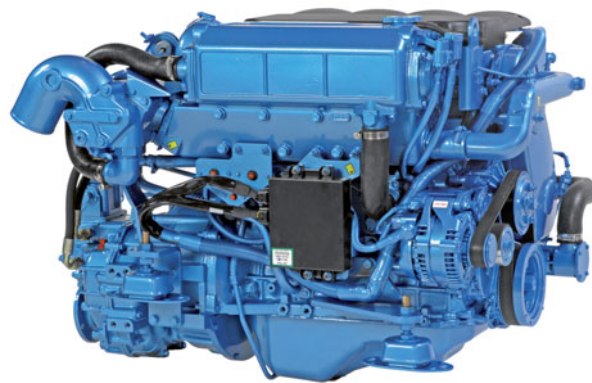

Proven Reliability from Experience

The T4.180 is developed based on the new engines with Common Rail direct fuel injection which has been used and proven reliable on the 4x4 Land Cruiser. The T4.180 is equipped with the latest innovations put in place by Toyota in terms of clean diesel engines.

Dynamic and responsive

Handling your boat equipped with this engine is a breeze. High torque at low rpm ensures a faster hole-shot and stunning acceleration. The low rated speed of 3400 enables you to cruise at comfortably low rpm's, reducing sound levels and fuel consumption. With this engine you can count on the most dynamic motorization with plenty of power reserve for all situations.

Ease of installation

The T4.180 mounting pattern is identical to the previous generation of 4 cylinder Toyota engines yet it is designed to fit into the smallest engine compartments.

Equipped with a hydraulic gearbox, the engine handles smooth and quiet while manoeuvring. This transmission can optionally be equipped with a Trolling Valve, which will allow you to adapt the boat speed to your fishing needs.

Common Rail Technology

This engine employs a Common Rail Fuel Injection system which stands for high torque and great fuel efficiency. The fuel rail maintains the fuel under constant, high pressure at all times allowing very responsive and accurate fuel injection under any condition.

The common rail system combined with 4-valve cylinder heads and two balancing shafts results in unprecedented smoothness providing very quiet and virtually vibration-free propulsion comfort.

Protecting the environment

The engine complies with the most stringent emission regulations in the world : EU-RCD, US-EPA and BSO.

Main characteristics

- Toyota base engine
- Common Rail injection system
- Turbo & Intercooler
- Big displacement
- High torque

Available transmissions

- ZF25A (hydraulic) 8° angle
- ZF45A (hydraulic) 8° angle
- ZF63IV (hydraulic) 12° angle
- TTM40A (hydraulic) 8° angle

Applications

- Semi-planning hulls
- Planning hulls

Technical specifications

Engine base	Toyota
Rated power (kW/hp)*	132.5 / 180
Rated rpm (rpm)*	3400
Displacement (cm ³ /in ³)	2982 / 181.97
Number of cylinders	4 in line
Bore and stroke (mm/in)	96 x 103 / 3.77 x 4.05
Compression ratio	17.9:1
Combustion system	Common Rail (Direct)
Intake	Turbo compressor & Intercooler
Cooling	Closed cooling with heat exchanger
El. equipment / Alternator	12V / 100A
Instrument panel	C4-T
Transmission	Mechanical or hydraulic gearbox
Engine Max Install. Angle	7° (dynamic)
Certifications	US EPA, BSO, EU-RCD
Dry weight with TTM40A (kg/lb)	362 / 798
Connections diameter	
Exhaust (mm/in)	90 / 3.54
Fuel (mm/in)	10 / 0.39
Sea Water (mm/in)	38 / 1.49

* At engine flywheel, according to ISO 8665-1

T4.180 engine

132.5 kW (180 hp)

Standard equipment

- Exhaust elbow
- Closed cooling with heat exchanger
- 4 meter electrical harness
- Fuel filter with water detector
- Oil filter
- Angled transmission 8°
- Owner's Manual
- Sea water pump
- Coolant circulating pump
- Fuel feed pump
- Control cables mounting points
- Integrated oil and fuel cooler
- Engine flexible mounts
- Electrical system 12V
- Thermostat

Optional equipment

- Additional alternators
- Trolling valve
- PTO Pulley
- A4 panel
- Separated instruments
- Sea water hoses
- Fuel hoses
- Sea water filter
- Flexible coupling
- Exhaust system

C4-T panel

- Ignition key / Start button
- Tachometer and hour meter / Voltmeter
- Battery charge warning light
- Engine control warning light
- Turbo warning light
- Preheating warning light
- Water in fuel filter warning light
- Oil pressure indicator
- Oil pressure warning light
- Coolant temperature indicator
- Preheating warning light

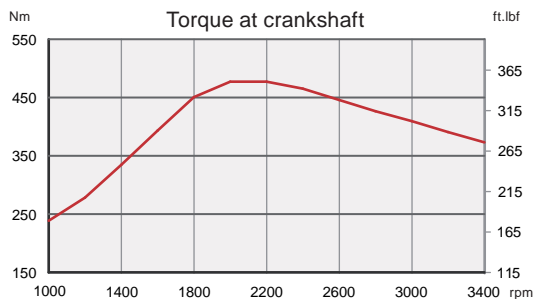
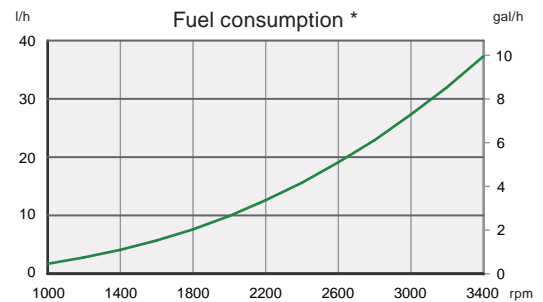
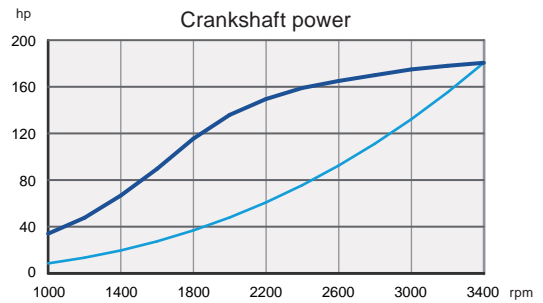
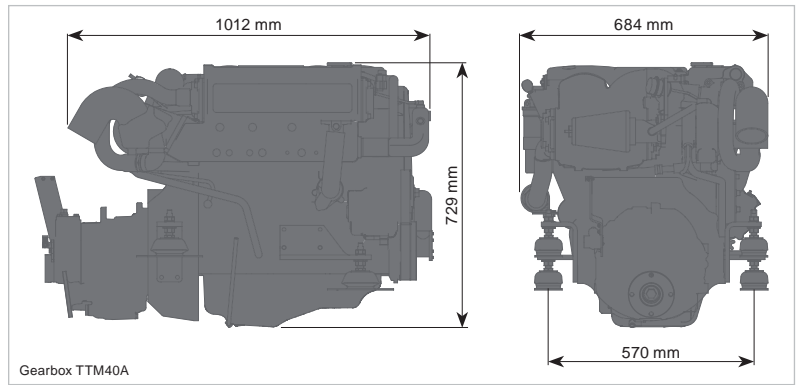
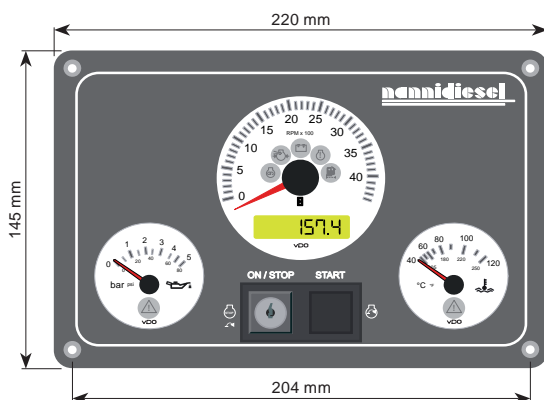

— Crankshaft power (hp)
 — Power calculated at propeller exp 2.5
 *Fuel consumption calculated at propeller load exp 2.5

Nanni Industries S.A.S. France
 11, Avenue Mariotte-Zone Industrielle
 33260 La Teste France
 Tel : + 33 (0)5 56 22 30 60
 Fax : +33 (0)5 56 22 30 79
www.nannidiesel.com



Your dealer